

多效蒸發於廠內水回收廢水 零排放之應用

許乘風

- 前言
- 蒸發原理簡介
- 蒸發器形式介紹
- 阿法拉伐蒸發系統介紹
- 蒸發器最常面臨問題
- 板式蒸發系統優點
- 板式蒸發系統適用範圍及實績

前言

- 半導體, 電子相關廢水處理成本愈來愈高, 難度也愈來愈高, 如何減廢甚至回收再利用一直是各廠重要而且關心的議題。
- 透過蒸發濃縮技術來達到：回收再利用, 減廢, 廢水前處理, 可大幅降低廢水處理成本, 甚至資源化廢棄物。

設備
事業部

船舶及發電

冷凍空調

衛生級設備

公用廠設備

OEM 設備

客戶服務

製程技術
事業部

食品技術

環保及能源

製程技術

生物科技

客戶服務

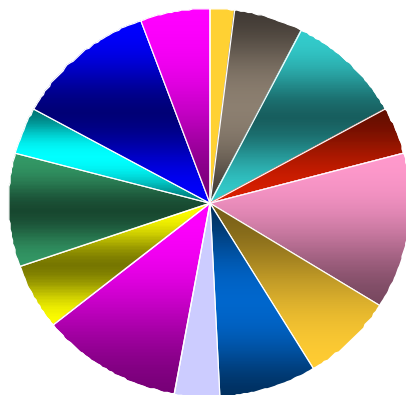

11 業務部



我們服務的台灣工業

飲料
生物化學
啤酒
化學
工程技術
魚類及肉類加工
食品加工
空調冷凍
船舶
採礦



原油及瓦斯
製藥
發電及電力輸送
電子與半導體
鋼鐵廠或金屬加工
澱粉
製糖
食用油
水與廢水處理

Water Cycle

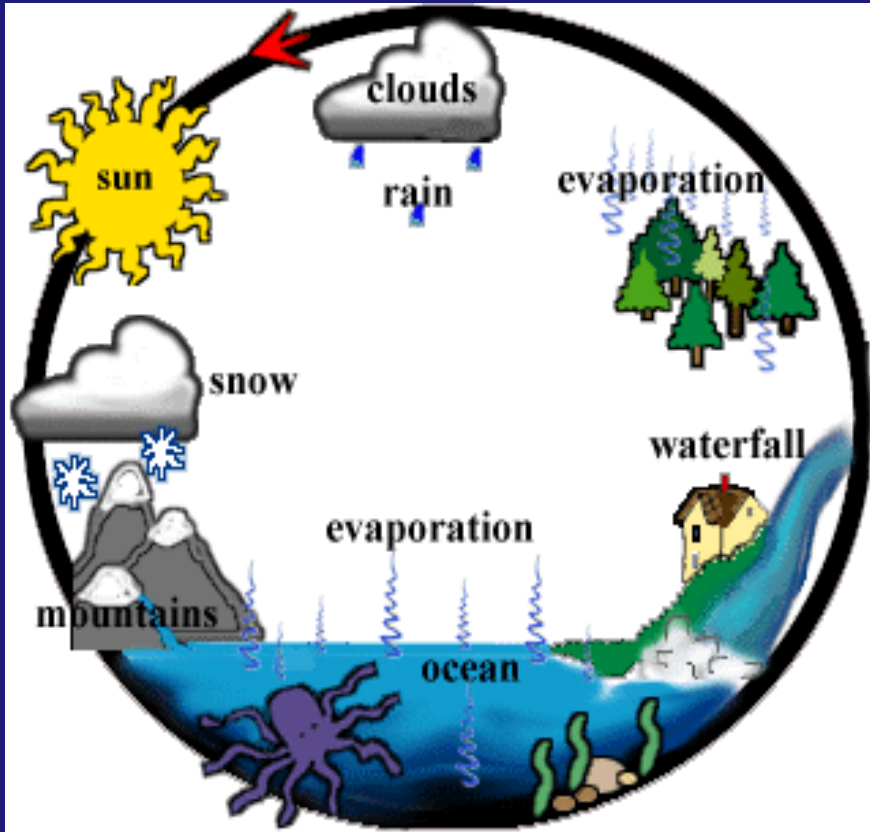

Water never stops moving. Snow and rain fall to the earth from clouds.

The rain and melted snow run downhill into rivers and lakes. Eventually the water flows into the ocean.

During evaporation, the water turns from liquid into gas, and moves from oceans and lakes into the atmosphere where it forms clouds.

Water cycle - in more details

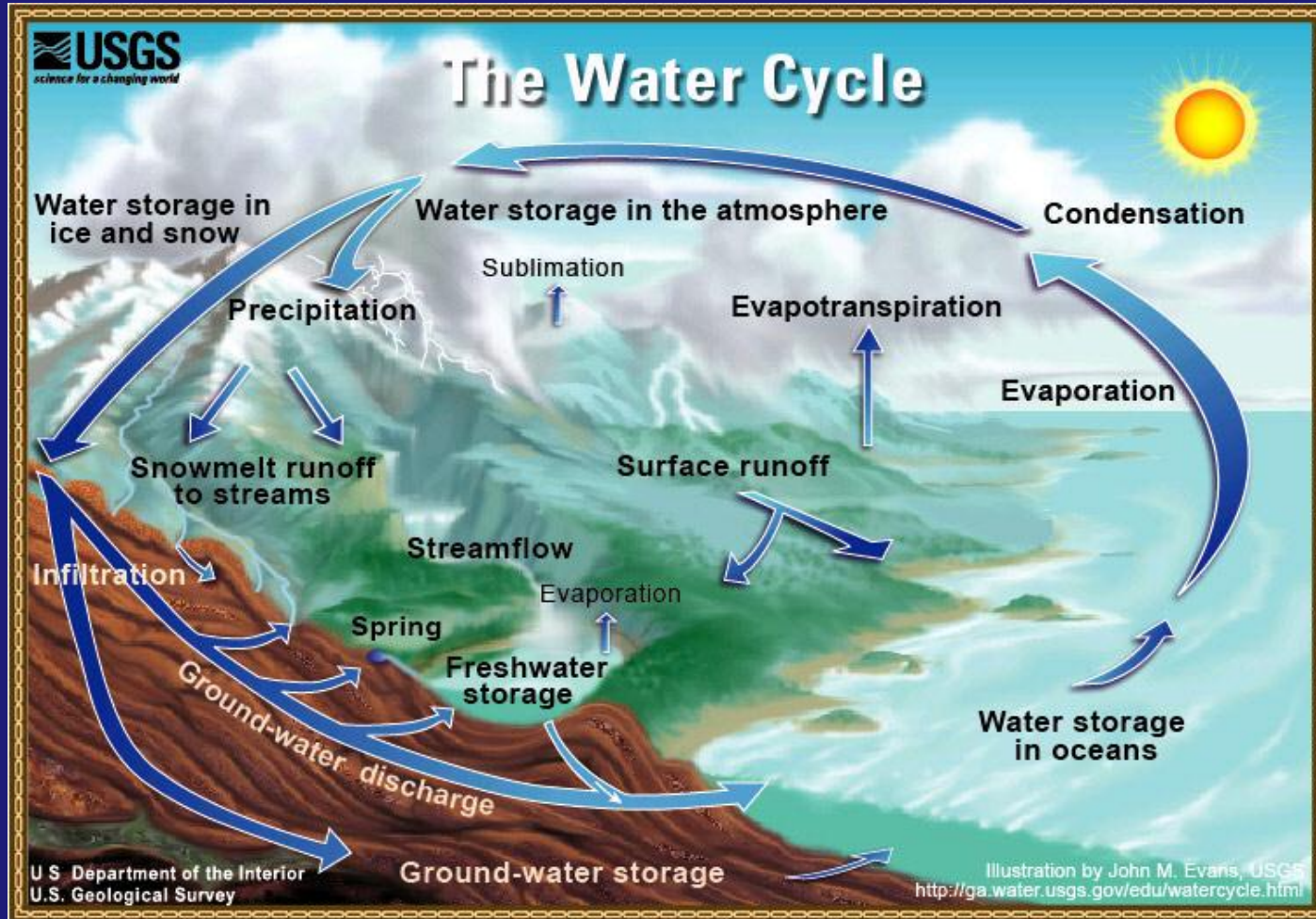

A World of Salt

Total Global Saltwater and Freshwater Estimates

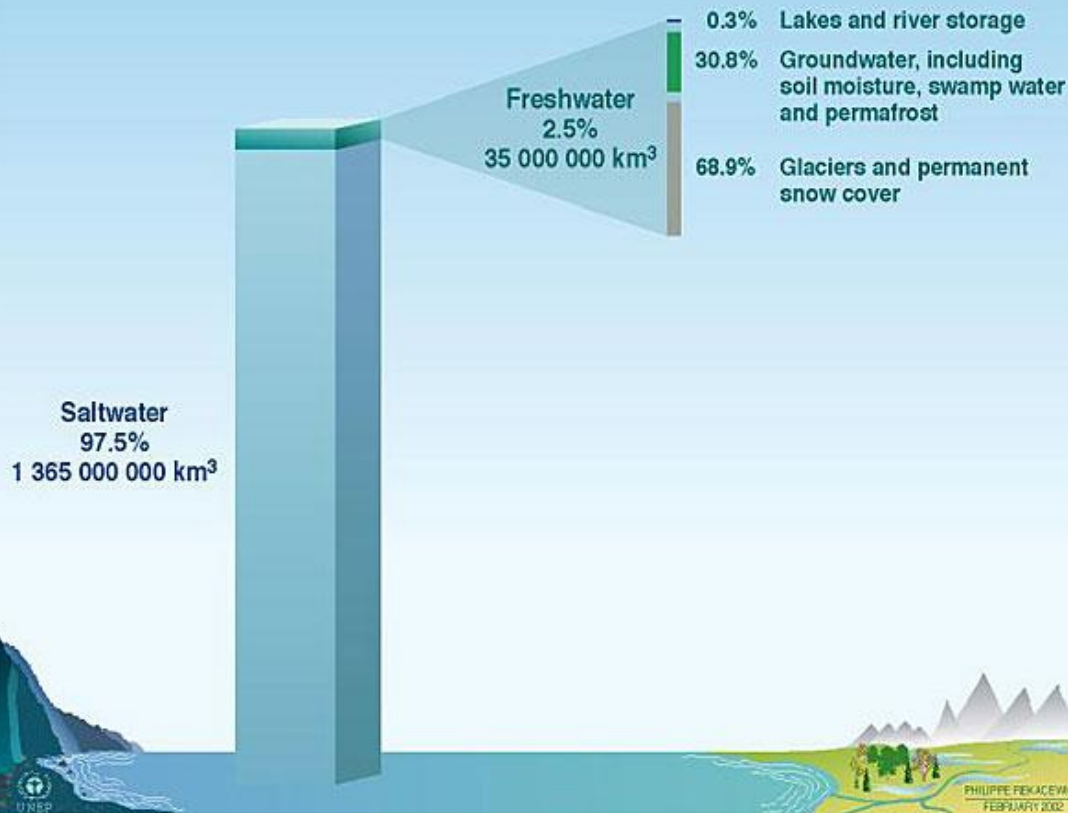

Source: Igor A. Shiklomanov, State Hydrological Institute (SHI, St. Petersburg) and United Nations Educational, Scientific and Cultural Organisation (UNESCO, Paris), 1999.

Of all the water in the world only 2,5 % is freshwater of **which** again the main part are tied in glaciers and permanent snow cover

Fresh Water Generator

- **Why Install a Fresh Water Generator – need for water ?**
 - Potable water
 - Sanitary use
 - Process use



Desalination



- The removal of ions or salts (artificial or naturally occurring) ...
- ... dissolved in an aqueous solution.
- Methods of desalination are
 - Membranes
 - Chemical reaction
 - Distillation

Water Desalination Principles

- **Distillation**

Thermal driven by hot water or steam:

- Fresh Water Generators (FWG)
- Multi Effect Desalination (MED)
- Multi Stage Flash (MSF)

Electrical driven:

- Mechanical Vacuum
Vapour Compression (VVC = MVC)

- **Membrane filtration**

- Reverse Osmosis (RO)
- Electro Dialysis (EDR)

- **Chemical Reaction**

for demineralisation of boiler feed
water

- Ion Exchange (IX)
- Electro De-Ionisation (EDI)

Desalination – Reverse Osmosis



Reverse osmosis (RO) is a filtration method that removes many types of molecules and ions from solutions by applying pressure to the solution when it is on one side of a selective membrane

Desalination – Electro Dialysis

Electrodialysis (ED) is used to transport salt ions from one solution through ion-exchange membranes to another solution under the influence of an applied electric potential difference.

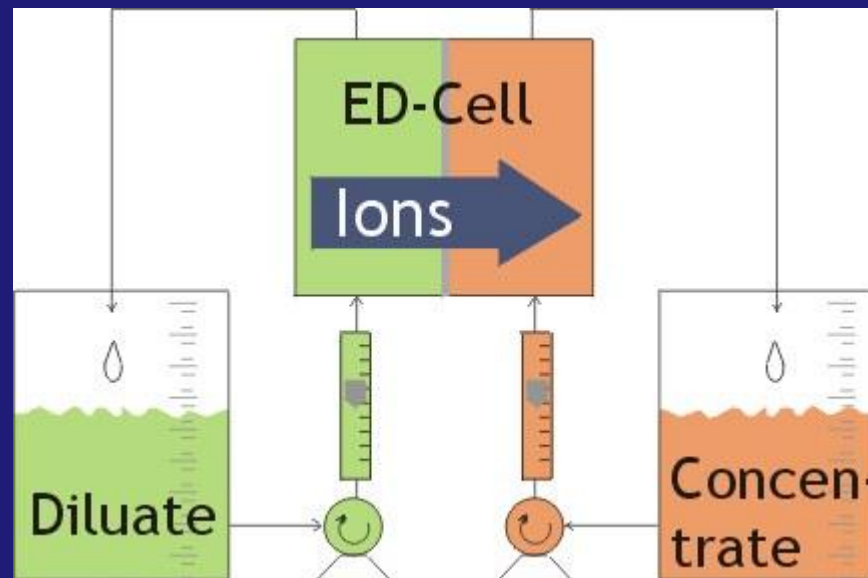

Desalination – Ion Exchange

Ion exchange is an exchange of ions between two electrolytes or between an electrolyte solution and a complex.

Typical examples of ions that can bind to ion exchangers are:

- H^+ (proton) and OH^- (hydroxide)
- Single charged monoatomic ions like Na^+ , K^+ , or Cl^-
- Double charged monoatomic ions like Ca^{2+} or Mg^{2+}
- Polyatomic inorganic ions like SO_4^{2-} or PO_4^{3-}



General Distillation Principle

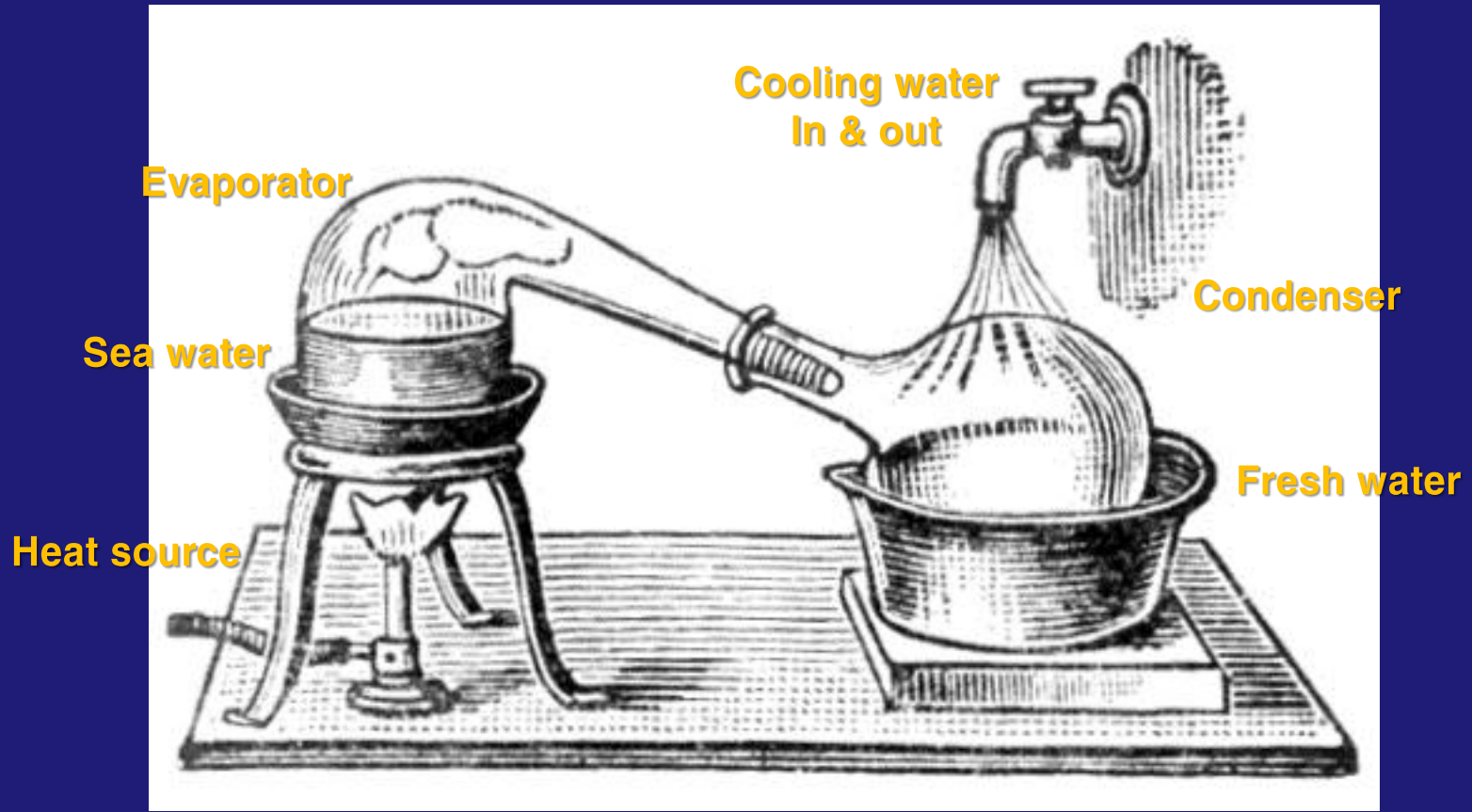

Possible Heat Sources

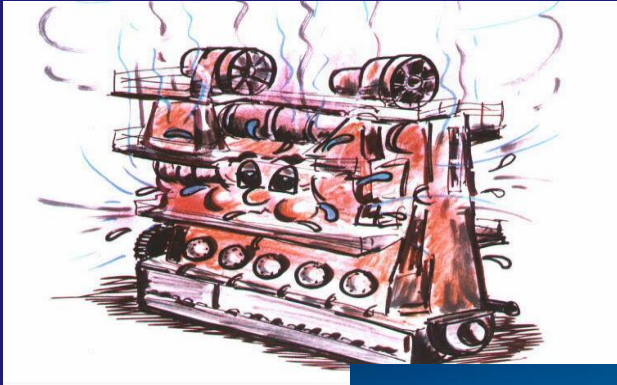

- Jacket Cooling or Hot Water



- Steam



- Electricity

Boiling Point Temperature & Pressure

Water boils at 100° C / 212° F



Sea level
Pressure = 1 bara

Water boils at 120° C / 248° F



Pressure cooker
Pressure ~ twice sea level
= 2 bara

Boiling Point Temperature & Pressure

Water boils at 84° C / 184° F



Mt. McKinley
Pressure = 0.56 bara

Water boils at 48° C / 118° F

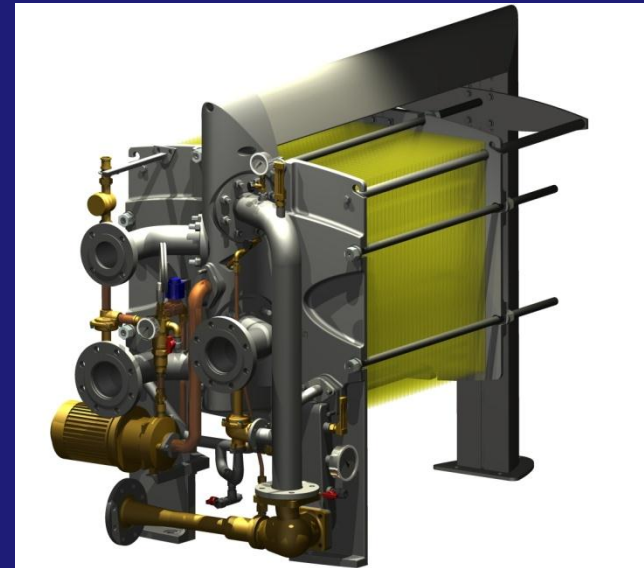

Alfa Laval FWG/Desalination plant
Pressure = 0.11 bara

Type of Evaporator

- Roberts (Rising Film)
- Falling Film Evaporator
- Plate Type

Rising Film - Roberts

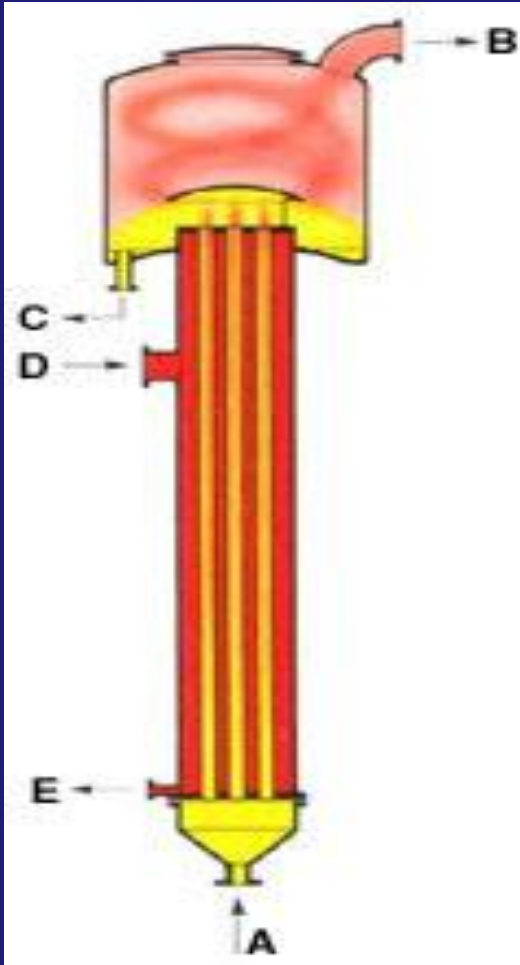

A: feed

B: steam (vapor)

C: concentrate

D: steam (heat source)

E: steam condense

Falling Film Evaporator

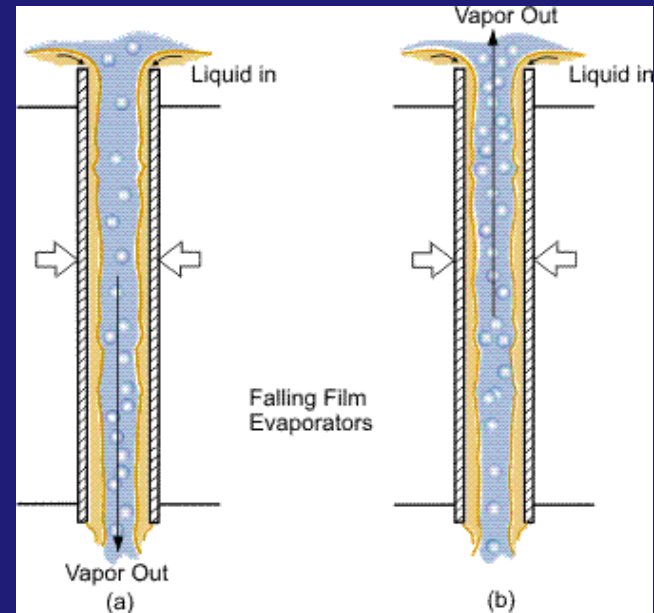
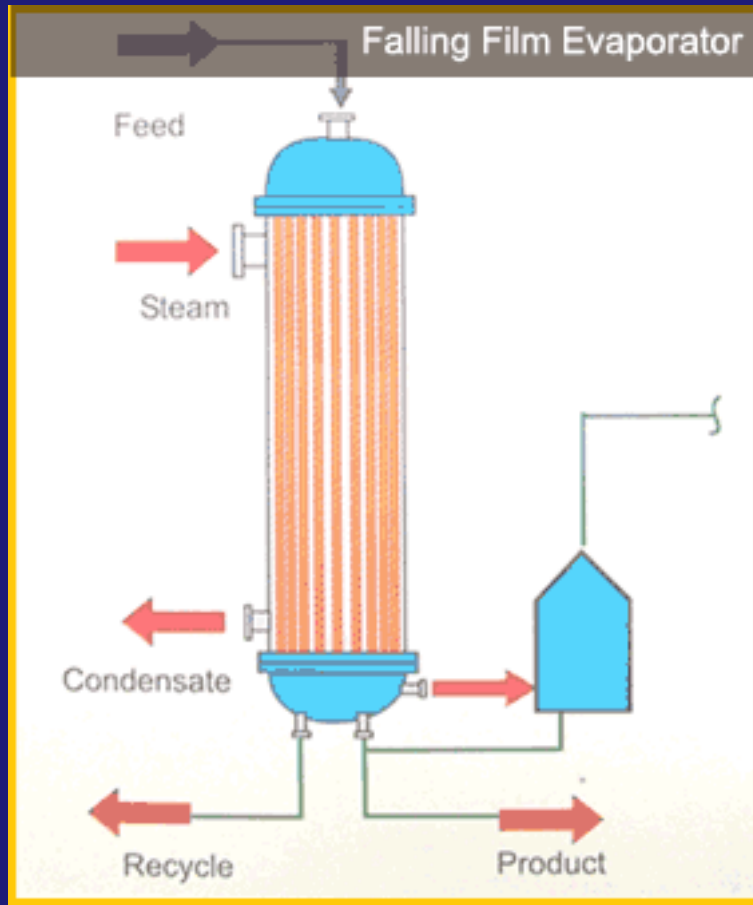

AlfaVap Vaporizer

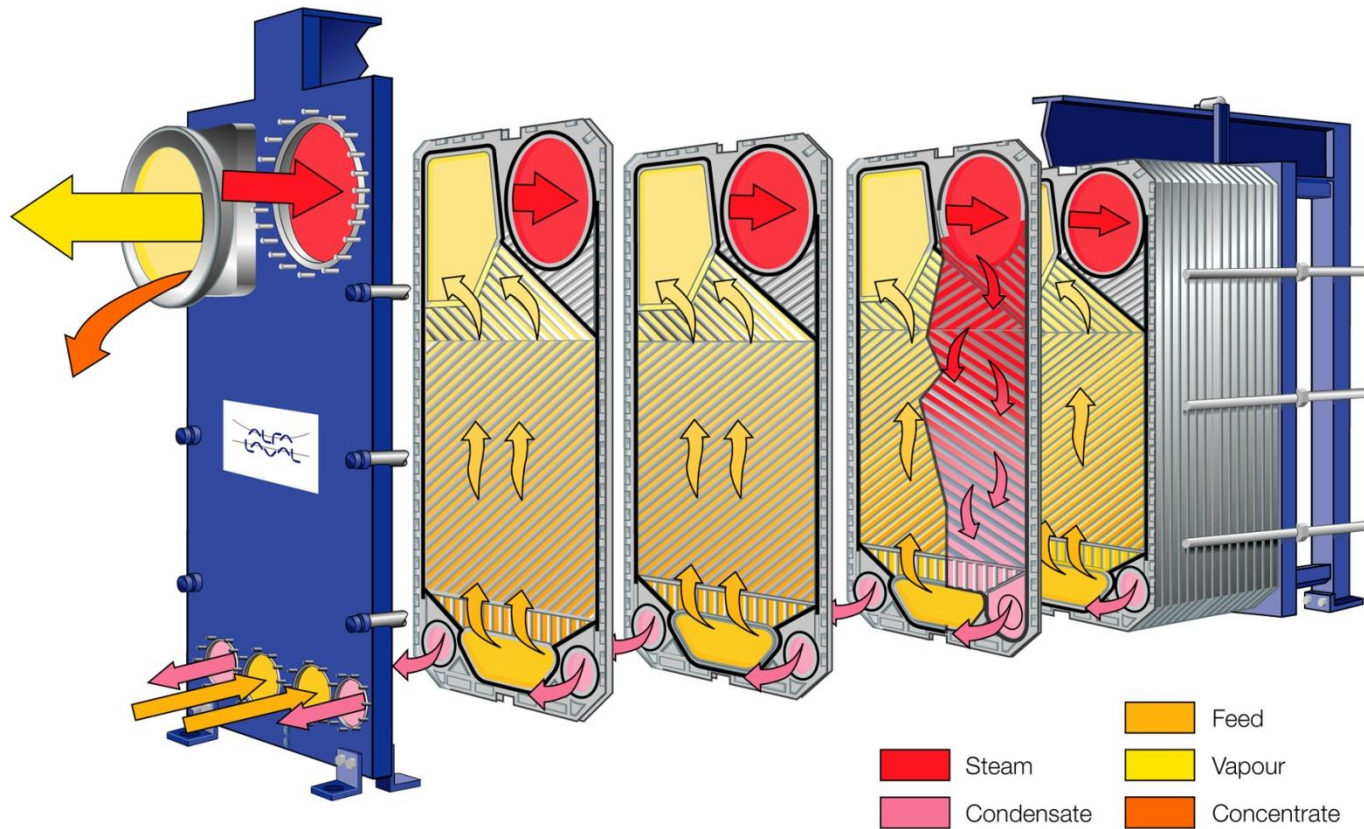

High thermal efficiency

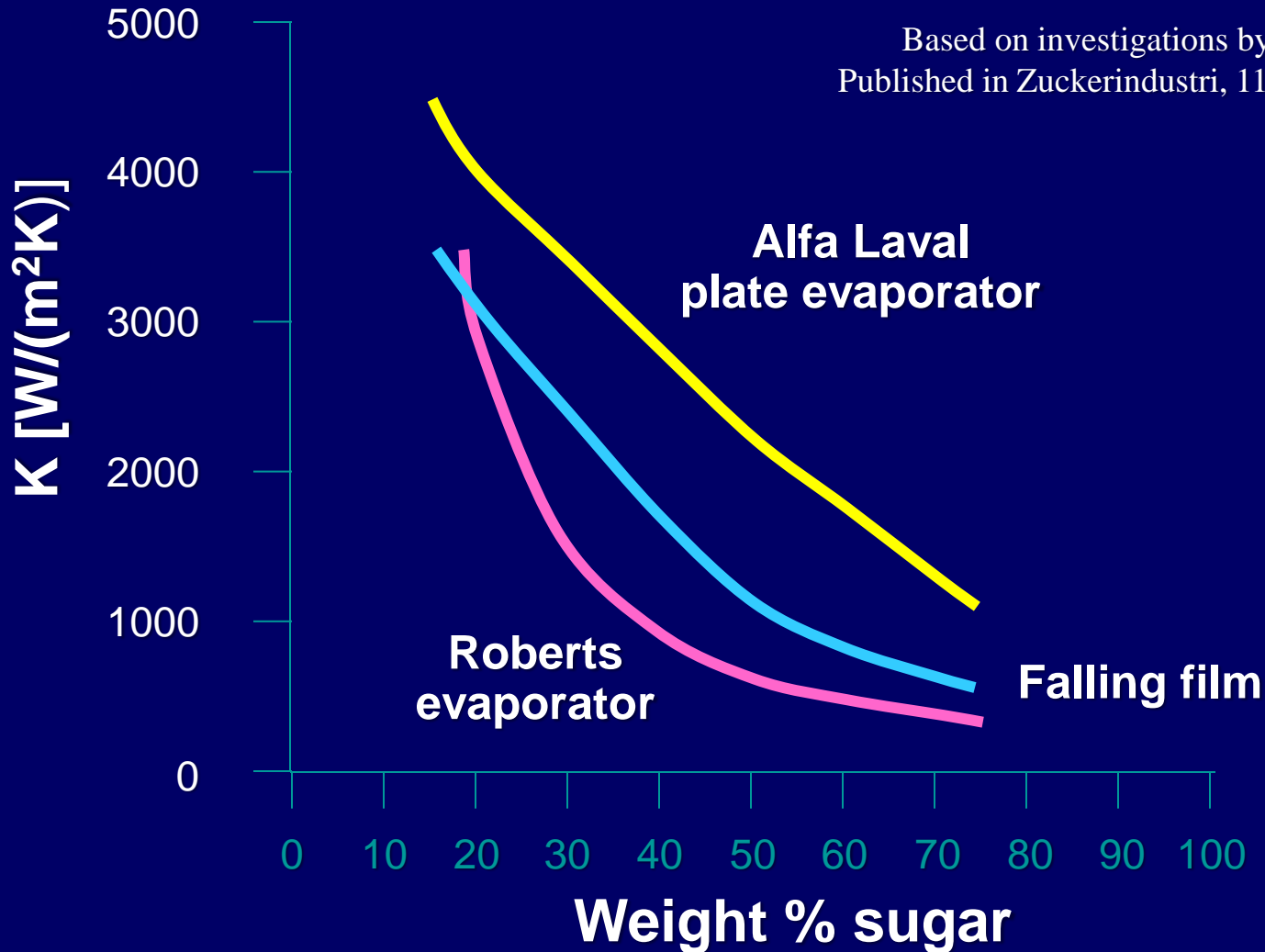

AlfaVap with an external cyclone separator

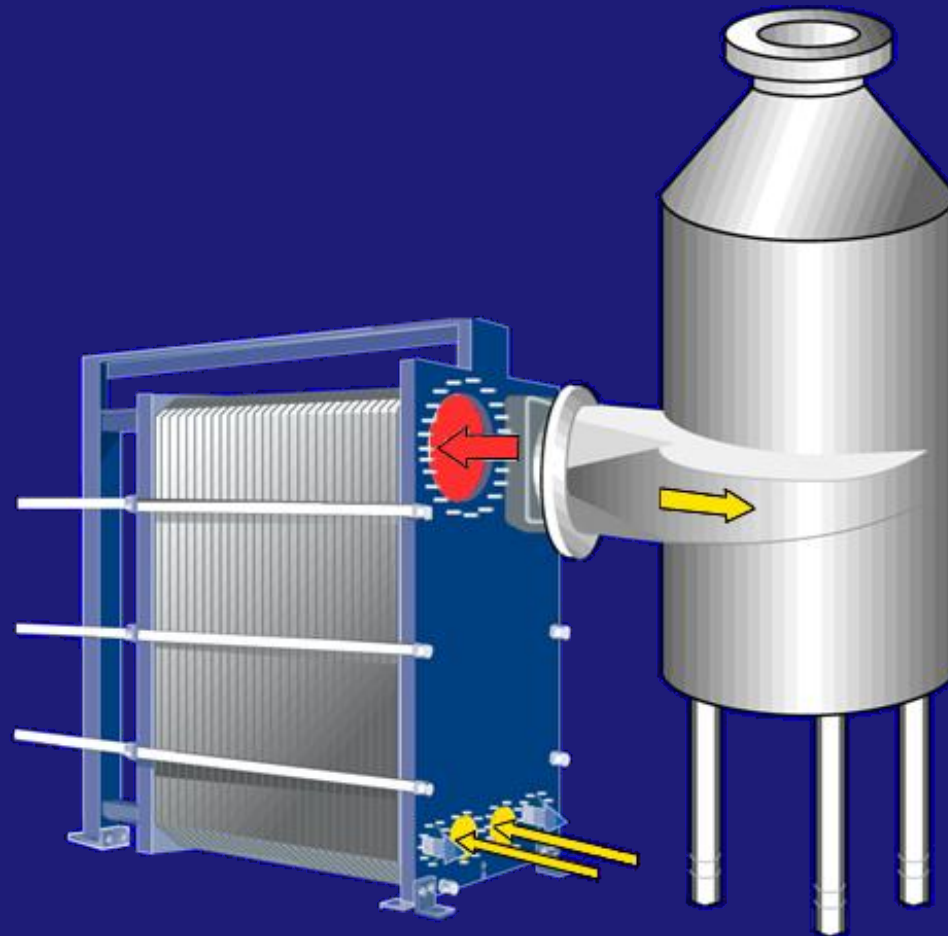

Space comparison between AlfaVap and shell-and-tube

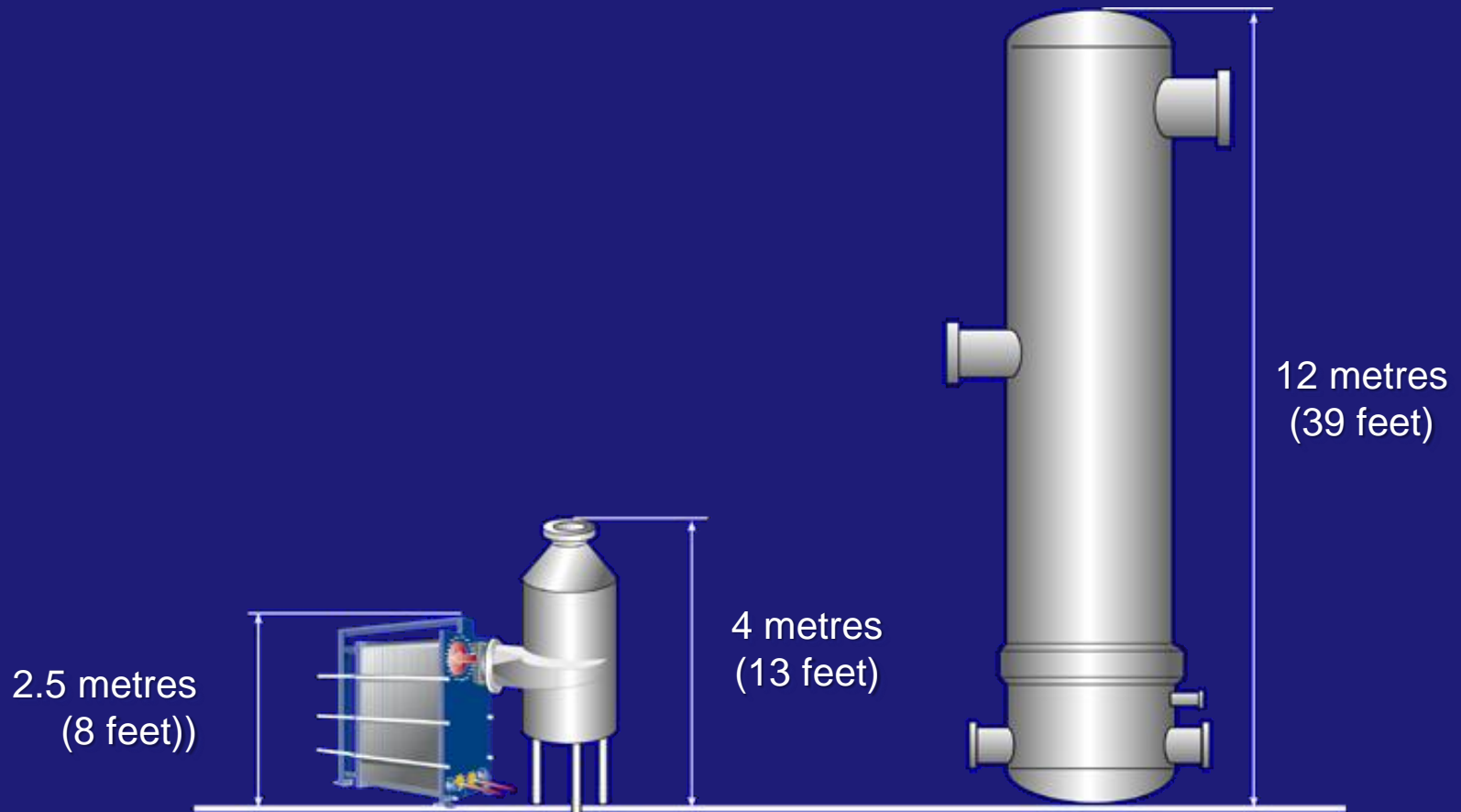

AlfaVap versus Falling Film S&T

8 metres

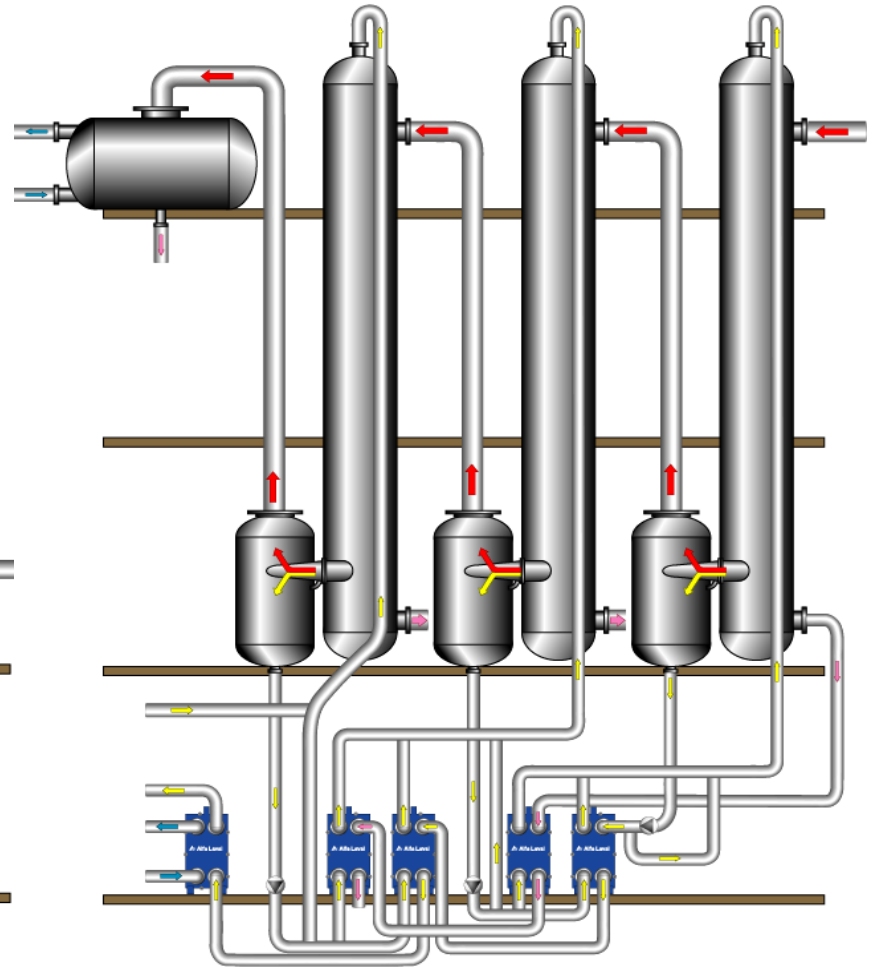
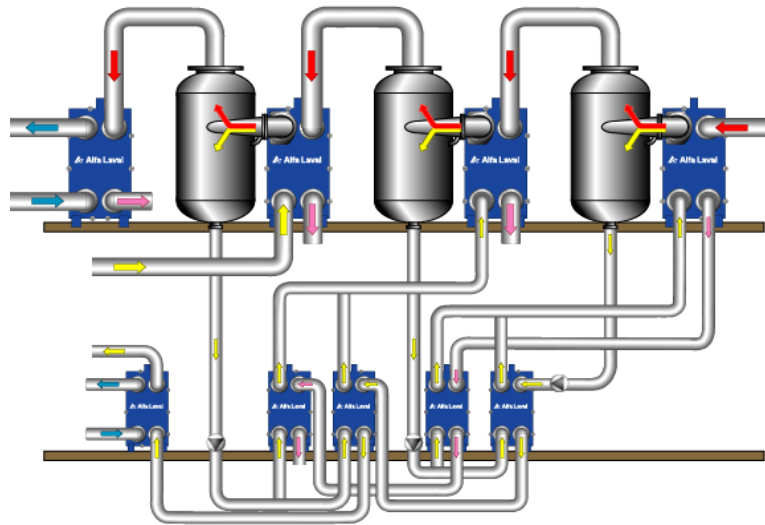

16 metres

Alfa Laval Desalination Technologies

- Single stage Fresh Water Generator (JWP, DPU, Dolphin or AQUA)
- Two stage Fresh Water Generator (DPU)
- Multi-Effect Systems (MEP)
- Multi-Effect Thermo Compression System (TVC)
- Vacuum Vapor Compression (VVC or ORCA)

Alfa Laval Core Products

single and double effect FWG units

- Vacuum Vapour Compression (VVC) by electrical energy:
20 – 70 m³/day



ORCA

- Fresh Water Generators (FWG), 1 and 2 effects by thermal energy:
10 – 70 m³/day



DOLPHIN



DOLPHIN (2 effect)



AQUA

Alfa Laval Core Products

MEP: Multi Effect Plate system
based on Distillation Technology

Capacity up to ~7.000 m³/day per unit



TVC: Multi-Effect Thermo-Compression System
Capacity: 300 – ~7.500 m³/day per unit



VVC: Vacuum Vapor
Compression System
300 – ~1.000 m³/day

www.alfalaval.com

MED = Multi Effect Desalination

MEP = MED with Plate Heat Exchanger Technology

Alfa Laval Core Products

**Type 3: 2-floor installation, AL
designed floor**

NaOH 180 tpd

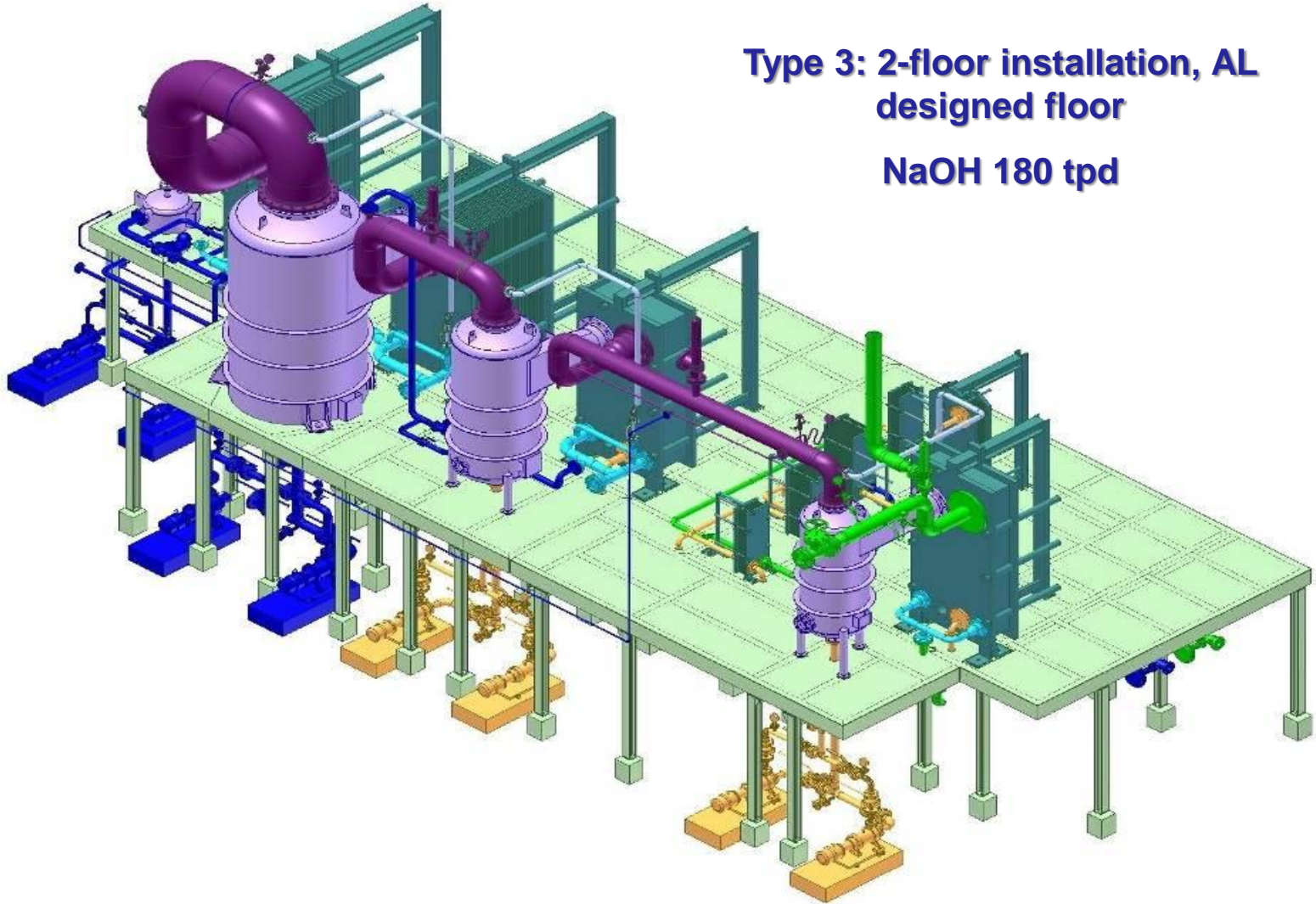

New state of art for Desalination

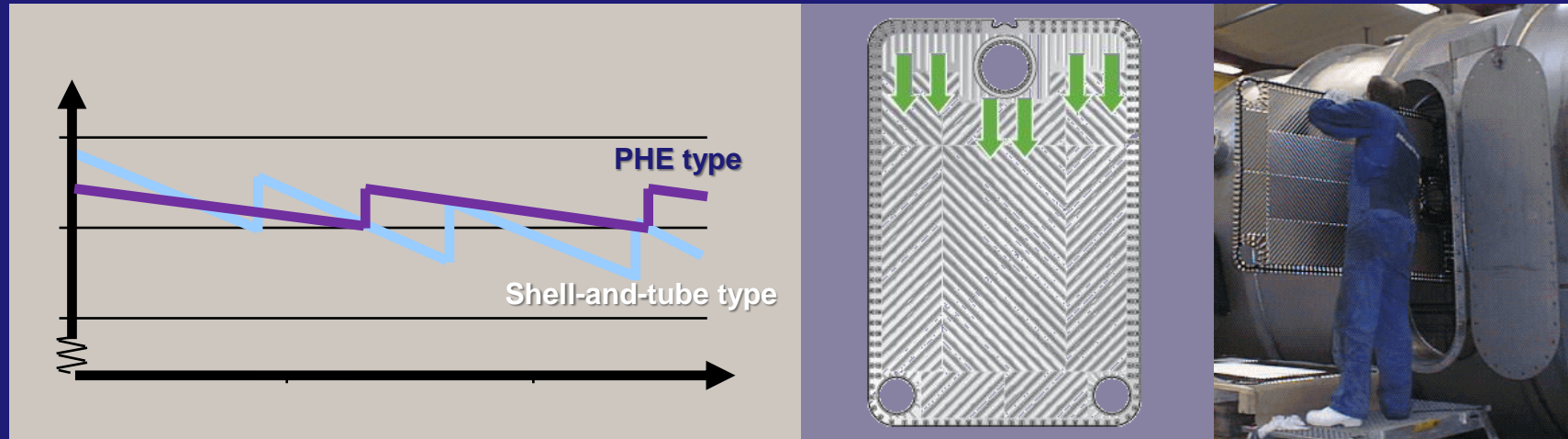

- 100% performance recovery after cleaning – no more loss of capacity
- Lowest scaling with controlled thin falling film – less cleaning
- No corrosion with titanium plate evaporators – no more leaking tubes
- Lowest total water production cost – with >30 years life time
- **-> but most important is reliable Plant Operation**

Superior Water Quality

Independent of Inlet Water Quality - Output < 5 - 10 ppm TDS

EXAMPLE:



Items	Highest desirable level	Maximum permissible level	Level from Alfa Laval XXXX desalination plants
Turbidity	5 units	25 units *	0.1 units
Color	5 units	50 units **	2 units
Odor	unobjectionable		none
Taste	unobjectionable		none
pH	7.0 - 8.5	6.5 - 9.2	5.5 - 6.5
NH3 -N ppm	0.05	-	0.05
NO2 -N ppm	-	-	0.01
NO3 -N ppm	40	50 - 100	0.5
Cl ppm	200	600	< 2.0
SO4 ppm	200	400	< 5
KMnO4 cons. ppm	10	-	< 2
T. S. ppm	500	1500	< 20
Hardness100 (ppm Ca CO3)	500	3	
Ca++ ppm	75	200	< 0.5
Mg++ ppm	30	150	< 0.5
T. Fe ppm	0.1	1.0	< 0.01
T. Mn ppm	0.05	0.5	< 0.005
T. Cu ppm	0.05	1.5	< 0.002
T. Pb ppm	0.1	-	< 0.005
T. Zn ppm	5.0	15	< 0.02
T. Cr ppm	0.05	-	< 0.005
T. Hg ppm	-	0.001	< 0.001
Phenol ppm	0.001	0.002	< 0.001
T. Cd ppm	-	0.01	< 0.005
Anionic detergents	0.2 (ppm)	1.0	-
Mineral oil ppm	0.01	0.3	-
General bacteria			
Coliform MPN 10	95% negative sample all year with 100 ml		100 % negative sample with 100 ml
E. Coli	negative with 100 ml sample		negative with 100 ml sample

ppm = mg/l,

*Turbidity units

** Platinum-cobalt colour scale

Typical Desalination System Design

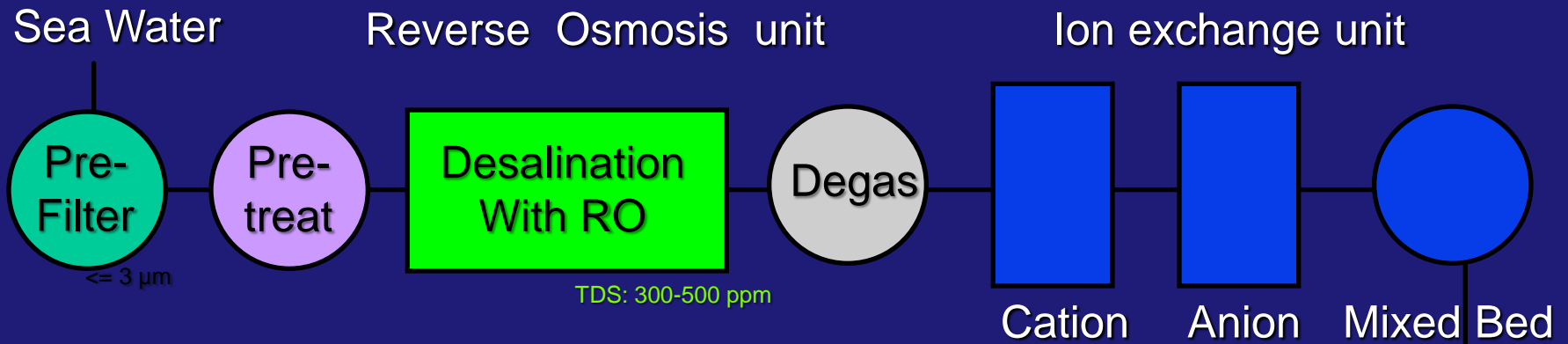

Primary Loop – desalination with demineralization

(Secondary Loop – for ultra pure Water)

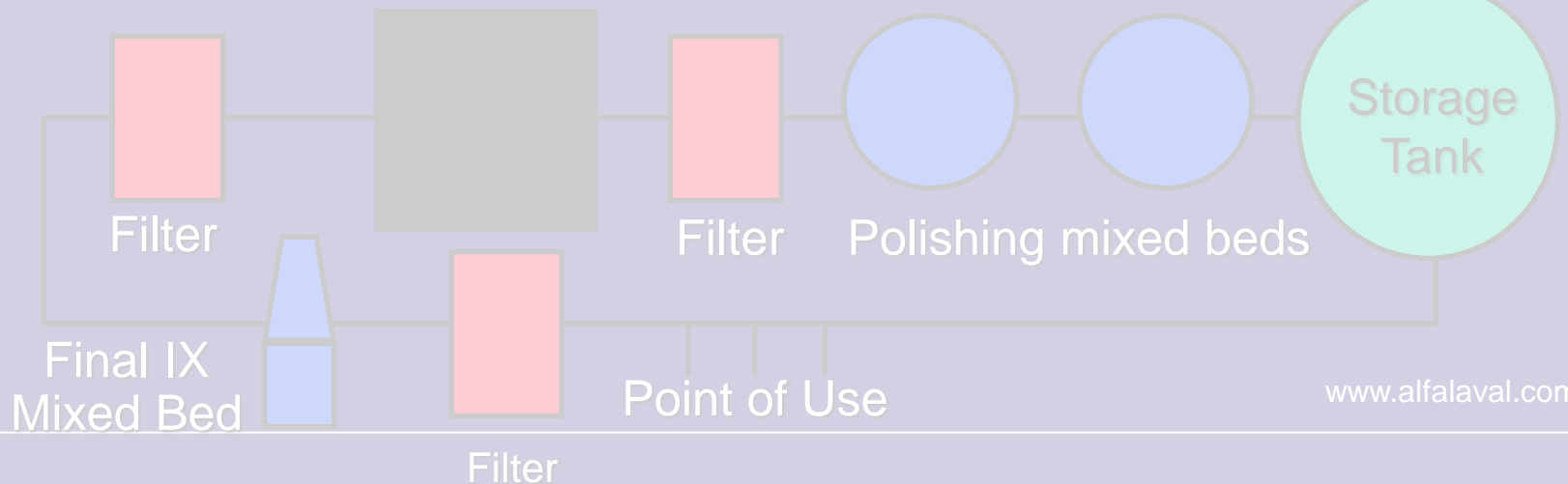

Typical Desalination System Design



Primary Loop – desalination with demineralization
(Secondary Loop – for ultra pure Water)

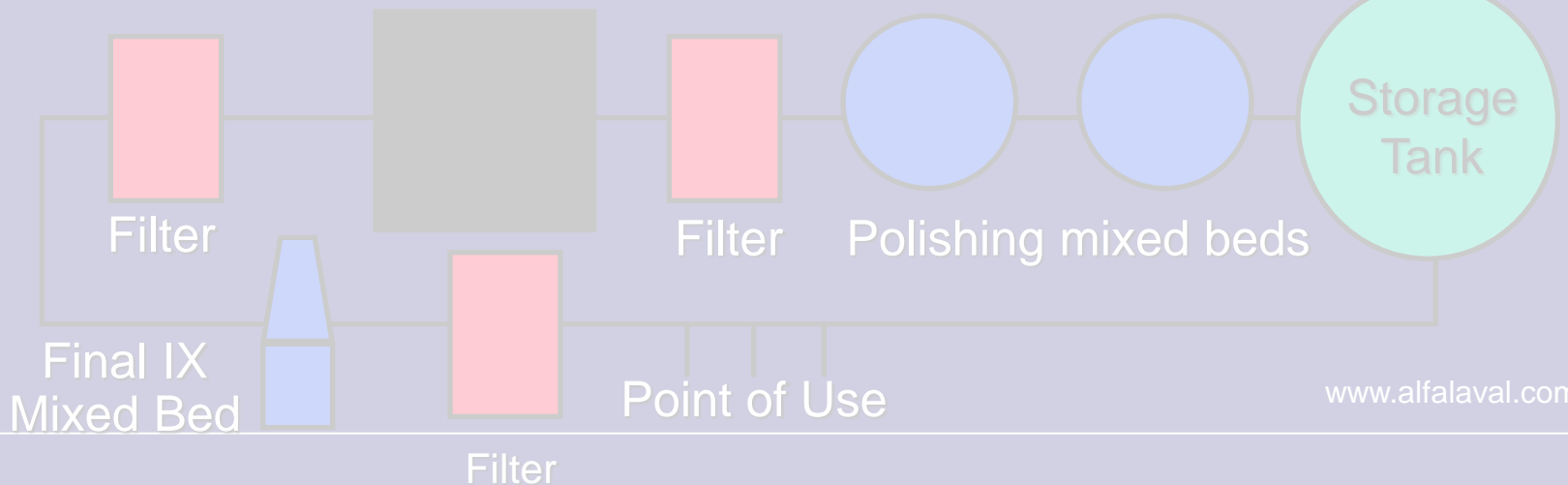

Small Unit

- Vacuum Vapour compression (VVC): 20 – 70 m³/day



- Thermal driven units, 1 and 2 effects: 1 – 70 m³/day



Main Process

1 effect FWG "DOLPHIN"

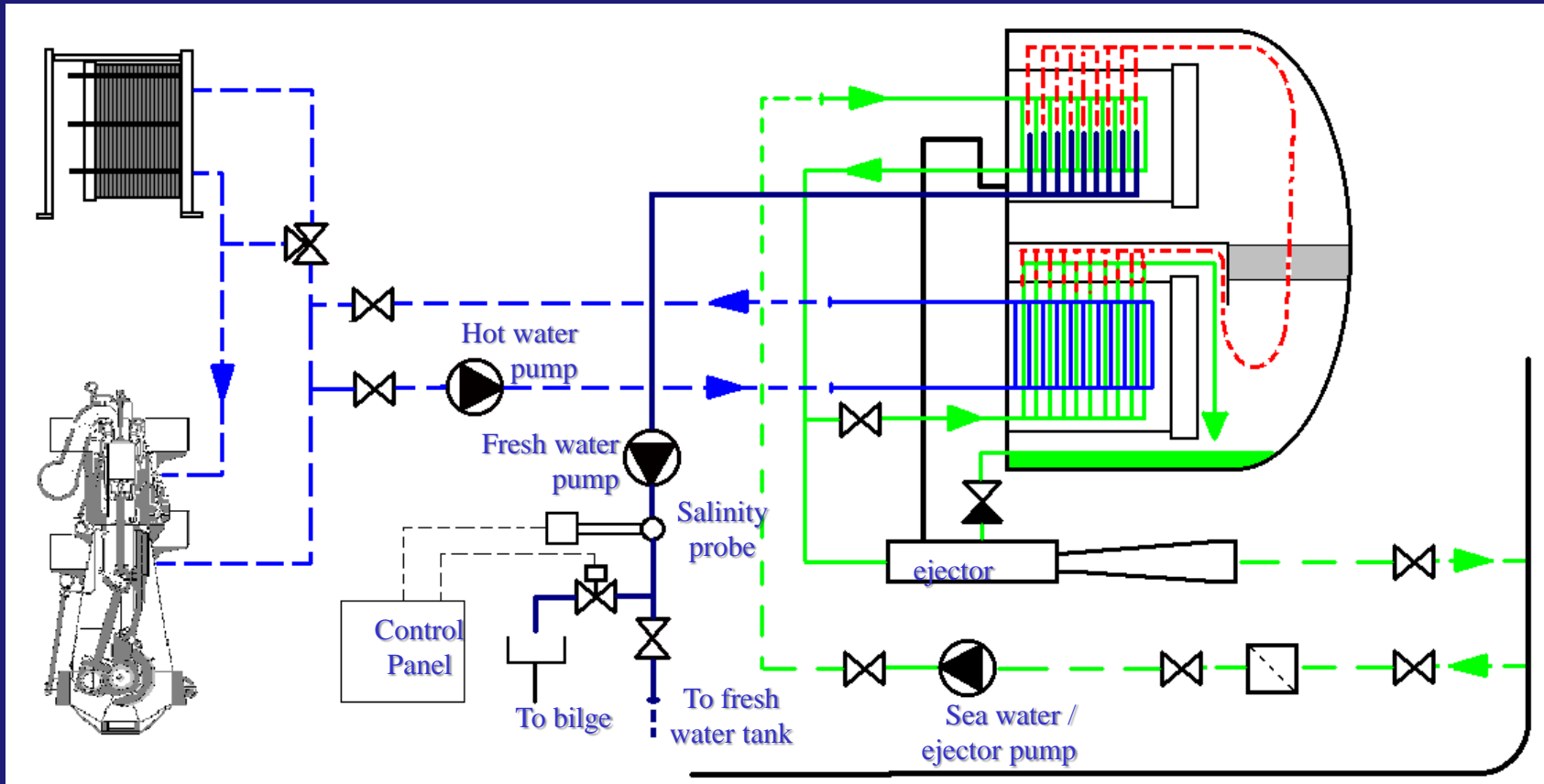

FWG process - one stage unit

FWG – traditional

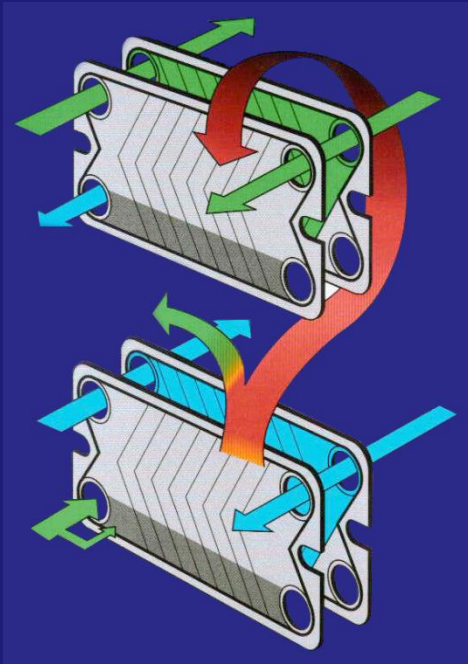

Condenser

Separator

Evaporator



FWG Traditional plate type

One effect

DOLPHIN - inside



Inside of DOLPHIN 70
2 effect



Inside of DOLPHIN 50
1 effect

We have what you need

- Single and two-stage units to meet your specific operating requirements
- The two-stage unit gives twice as much water on a given amount of energy



Single and two-stage units

Aqua

- Based on plate & frame concept
 - 3-in-1 plate design
- Separator vessel excluded
 - Capacity 10-60 m³/day
 - Water quality < 5 ppm



OPEX reduction	CAPEX reduction
<ul style="list-style-type: none">• Less sea water usage• Less pumping costs & electricity consumption• Longer maintenance intervals	<ul style="list-style-type: none">• Reduced weight• Less piping and -pump cost easier installation• Longer lifetime• Upgrade functionality

Less emissions and lower total life cycle cost

AQUA

PHE-concept with Titanium Plates

Latest Advances in
Desalination Units
with Titanium Plates



3-in-1 plate technology
with integrated

- Evaporator
- Separator
- Condenser

FWG process - one stage unit

FWG – traditional

“AQUA” design

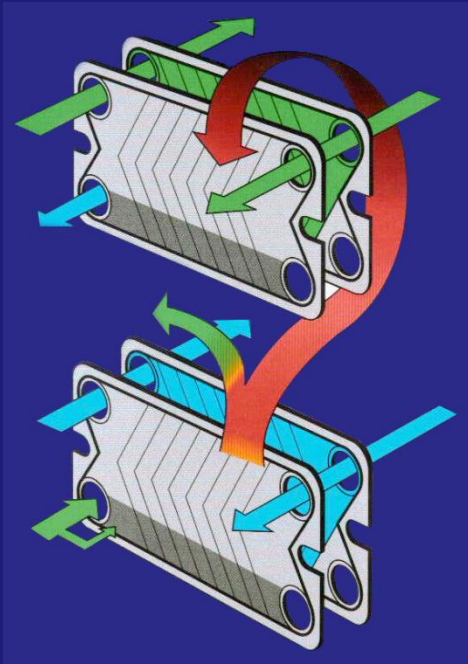

Condenser

Separator

Evaporator

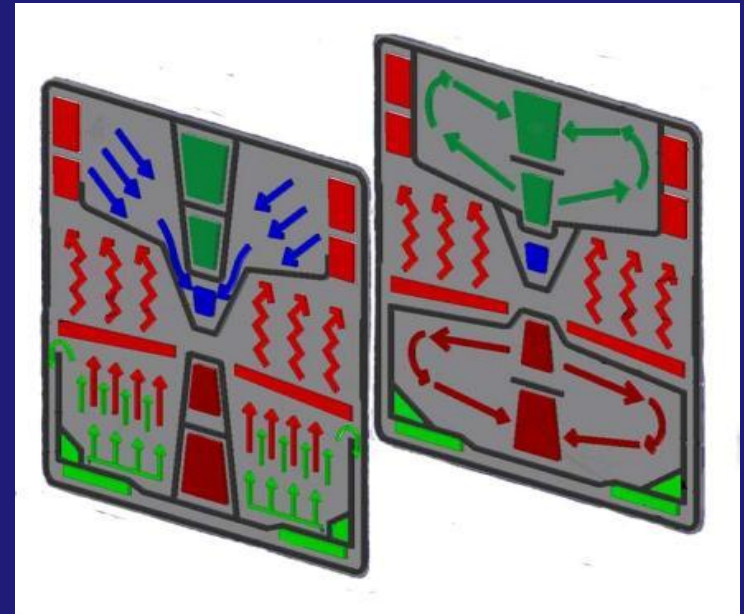

Process plate

Utility plate



FWG
Traditional
plate type



AQUA:
3-in-1 plate technology

Process and products

Fresh water can be produced from sea water with:



MEP Multi Effect Desalination (MED)

Waste heat energy
as hot water or LT steam
in small fresh water
generators and large
Multi-Effect Plate Distillers



TVC Thermo Vacuum Compression

Low pressure steam
with high efficient
Thermo Vacuum
Compression distillers



VVC Vacuum Vapour Compression

Electrical driven
with stand-alone
Vacuum Vapour
Compression distillers

MED X-Ray view of PHE arrangement



Alfa Laval Multiple Effect Distiller
Type: MEP – 4 effect

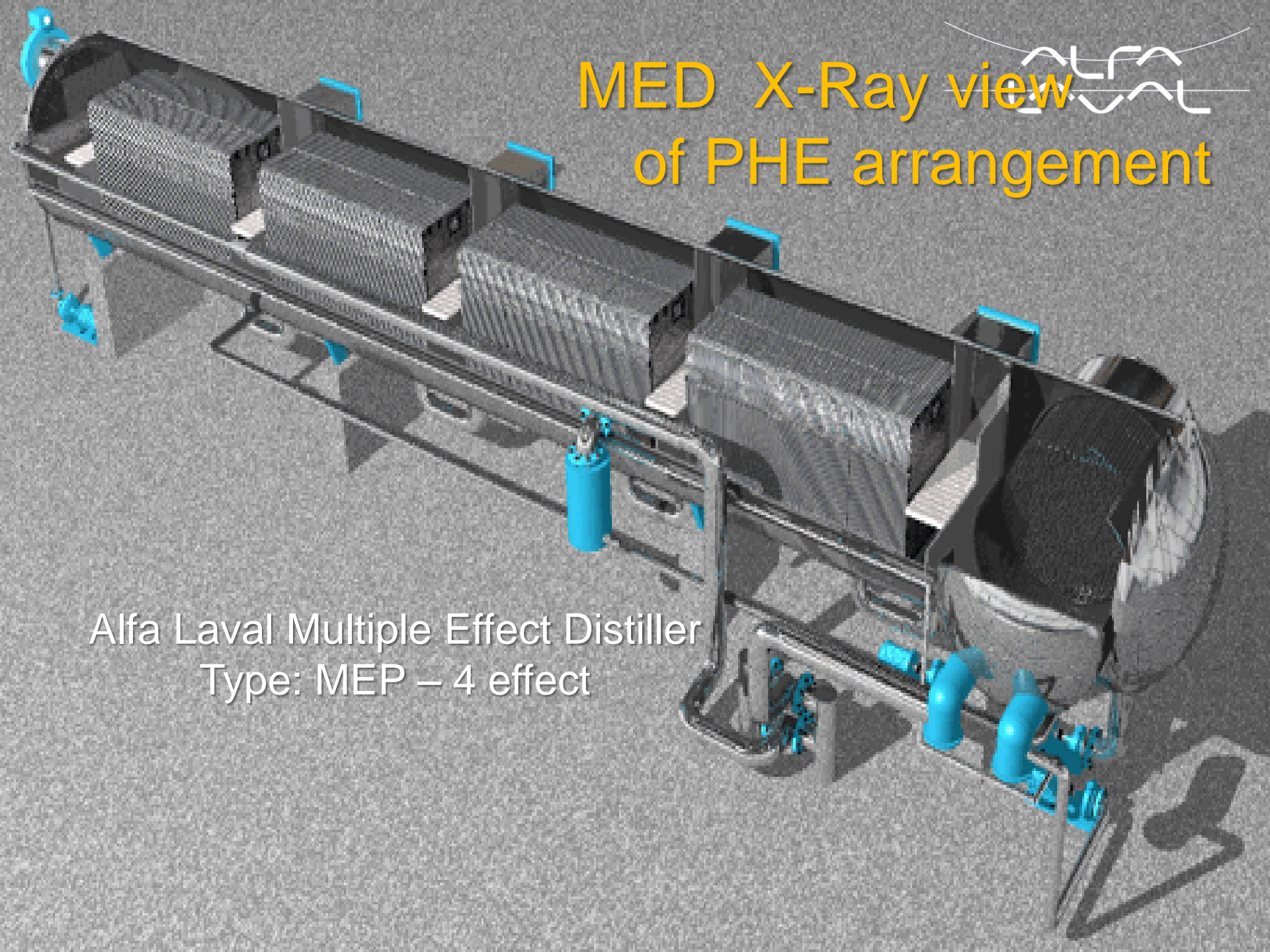

Vista Rayos X para arreglo PHE en MED

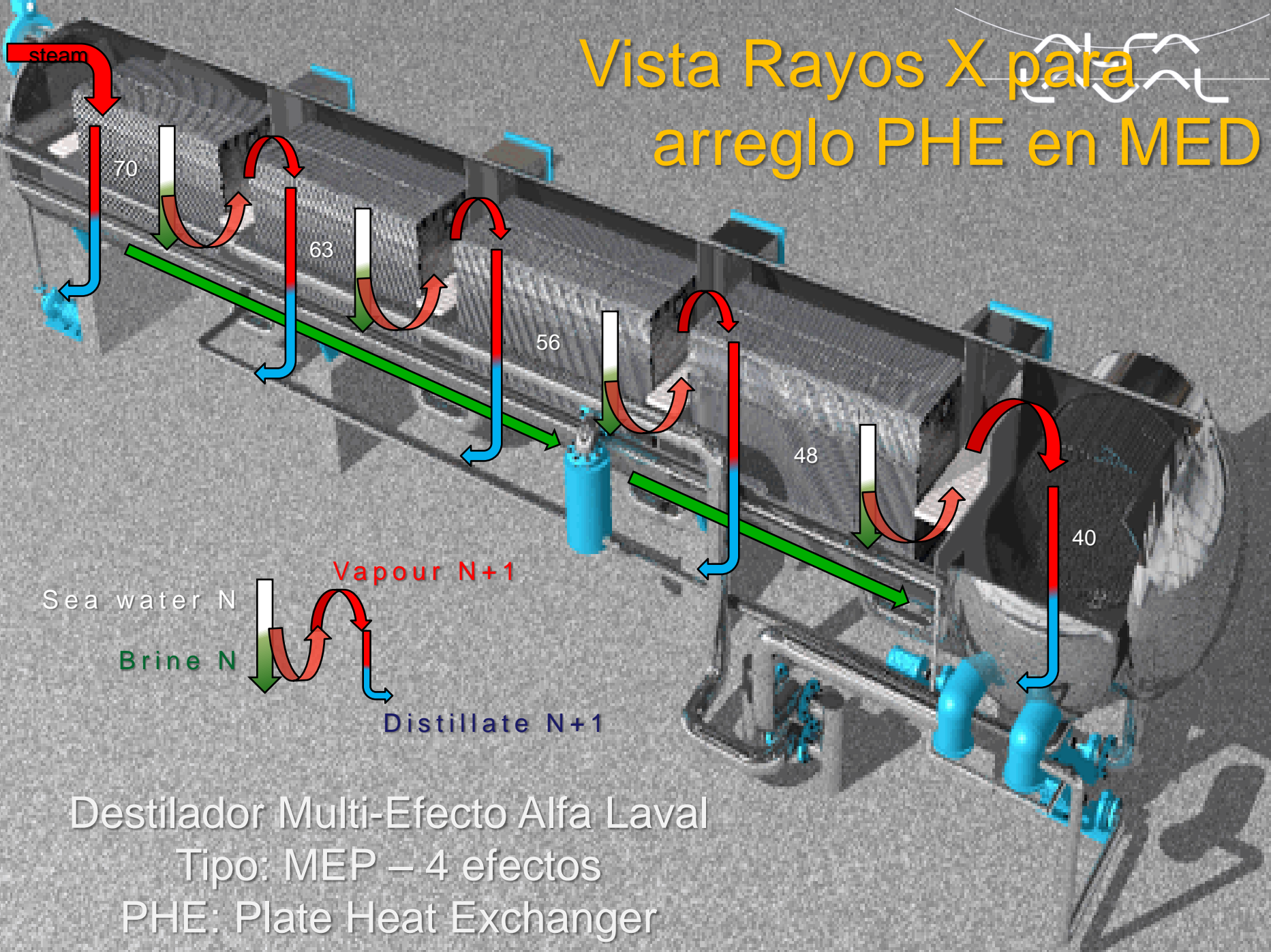

Destilador Multi-Efecto Alfa Laval
Tipo: MEP – 4 efectos
PHE: Plate Heat Exchanger

PHE CONFIGURATION

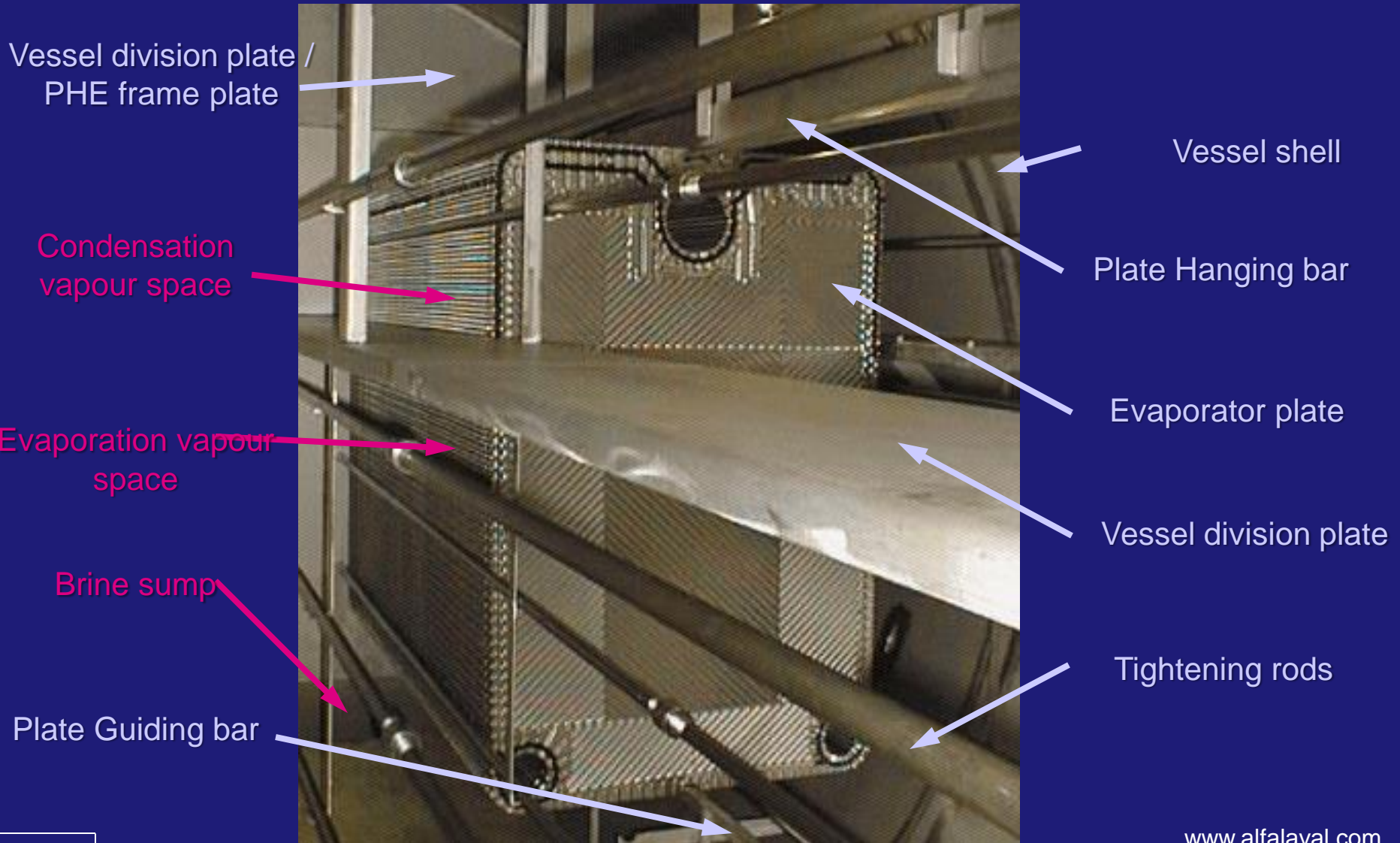

Evaporation plate channel

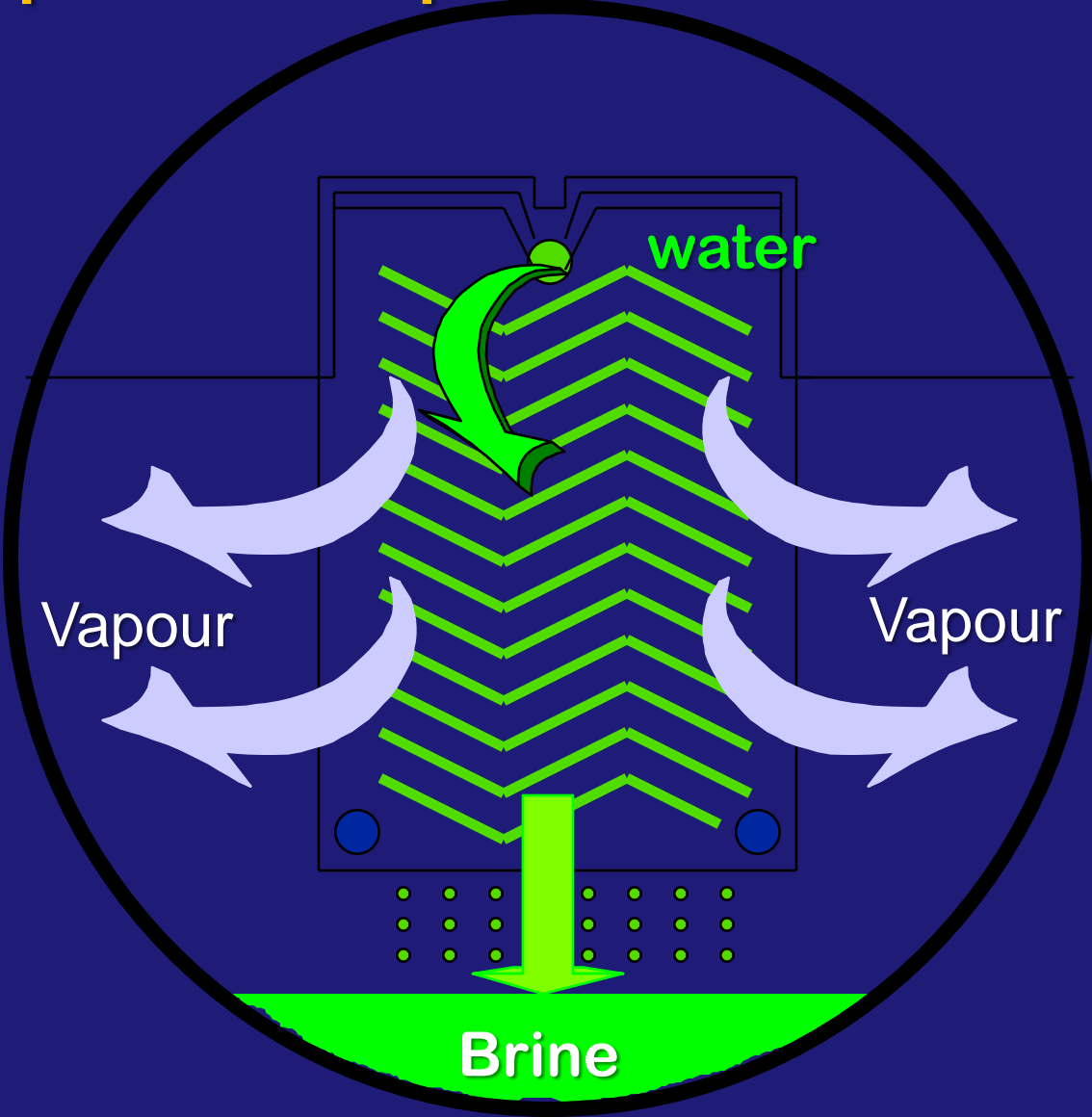

Condensing plate channel

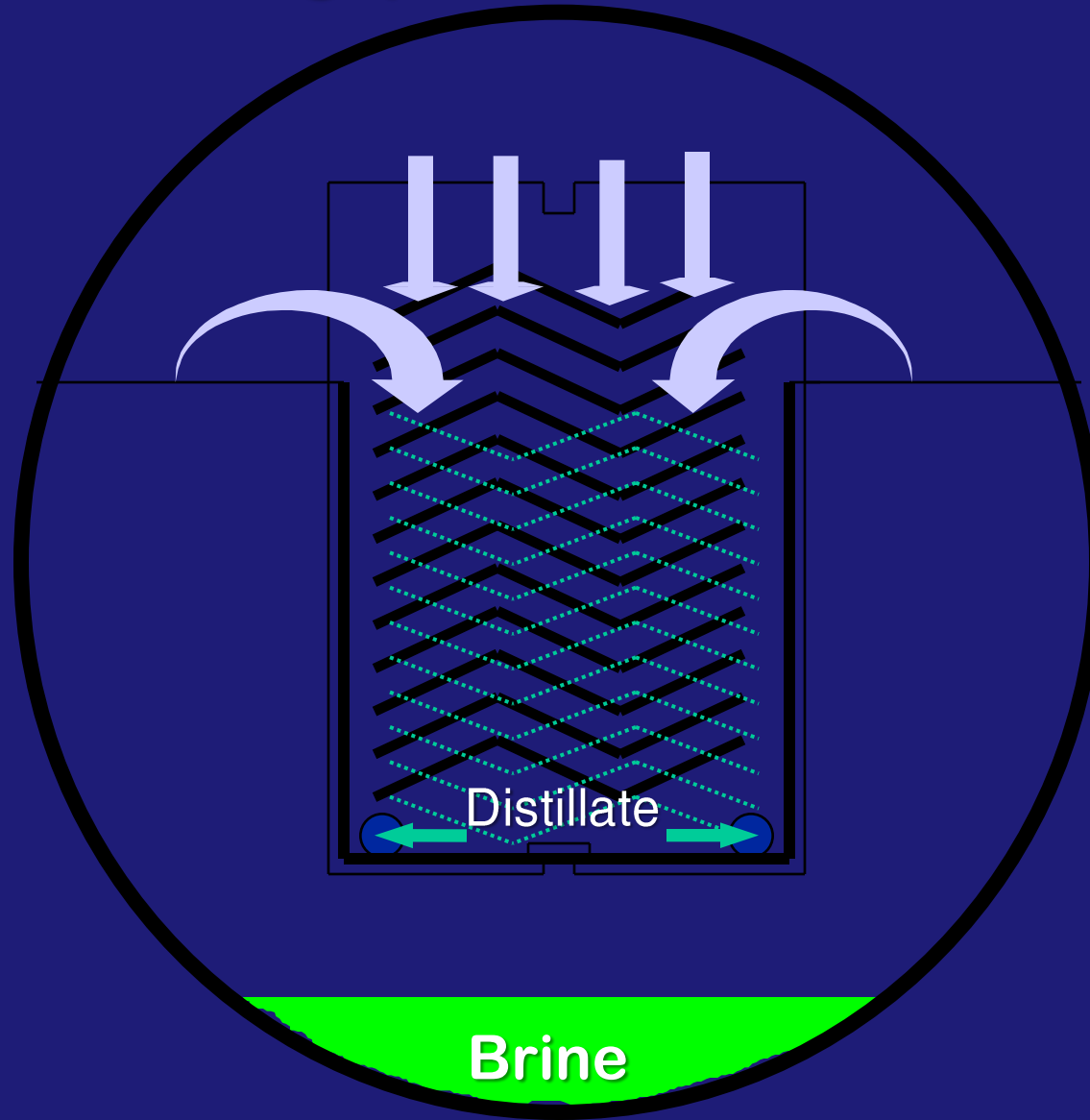
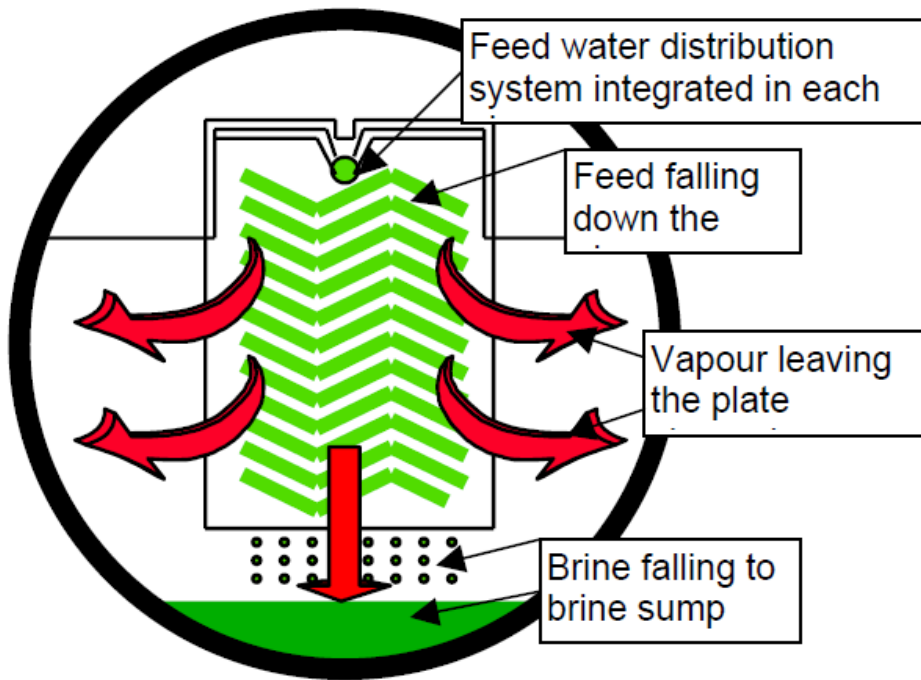
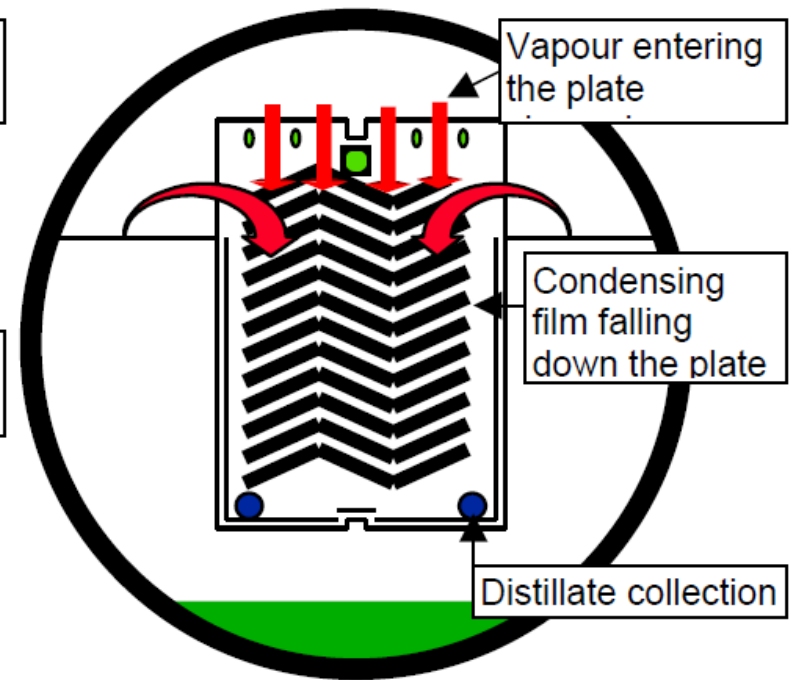

Plate Channel Arrangement

Evaporation Plate Channel



Condensation Plate Channel



Alfa Laval MEP Effect Working Principle

